



Ruger MARK III and 22/45 LCI Filler Plate Installation Instructions

V1.2

www.tandemkross.com

For more info or support contact
CustomerService@tandemkross.com

Attention:

Before you begin be certain that the firearm has no rounds in it. Always handle a clear and safe firearm.

You should be comfortable with the disassembly of the Mark III 22/45 down to the field cleaning level before performing this installation.

You will need:- 1) Magnet.

Installation Tip: Before you install the LCI Filler, thread the set screw all the way in and out again while it is out of the gun. The threads are tight from the machining process and this will ensure a good fit and proper threading of the set screw.

The TANDEM KROSS LCI Filler is designed to fit into the largest variety of MARK III and 22/45 models. The fit may vary from model to model. Some fine tuning may be required on some models. However, on most models the LCI will be a tight fit.

1. Locate the pin on the bottom of the barrel that retains the LCI.



2. Using the Magnet, remove the pin. It helps to move the magnet along the side of the barrel if coming from the top does not work.

Note: Some Ruger 22/45 LITE models can have pins that are extremely difficult to remove since the aluminum sleeve wasn't perfectly aligned over the steel barrel. This pinches the LCI pin. We recommend putting Kroil or WD40 on the pin, hold the barrel in its natural orientation, and then hitting upward next to the pin with a rubber mallet while holding the magnet on the head of the pin. Once it starts exiting the hole, the pin may require pliers to pull it out all the way.

3. Align the TANDEM KROSS LCI Filler plate to the opening. The tab with the hole is inserted toward the front of the gun.

4. Install the provided set screw with the allen key.

*We recommend using Blue Loctite on the set screw so that it firmly stays in place while shooting, but is still able to be removed for whatever reason later.

*While tightening the screw some adjustment of the LCI cover is possible to get the alignment the way you like it. Do not over tighten.



5. If your LCI is not fitting into the slot: On some models of 22/45 LITE the barrel is twisted in the aluminum shroud and it comes down into the LCI slot area where the flag portion of the LCI replacement needs to be seated into the slot. Looking into the slot if you see a portion of the barrel coming down into the slot and the LCI does not fit you will need to sand the edge of the LCI.

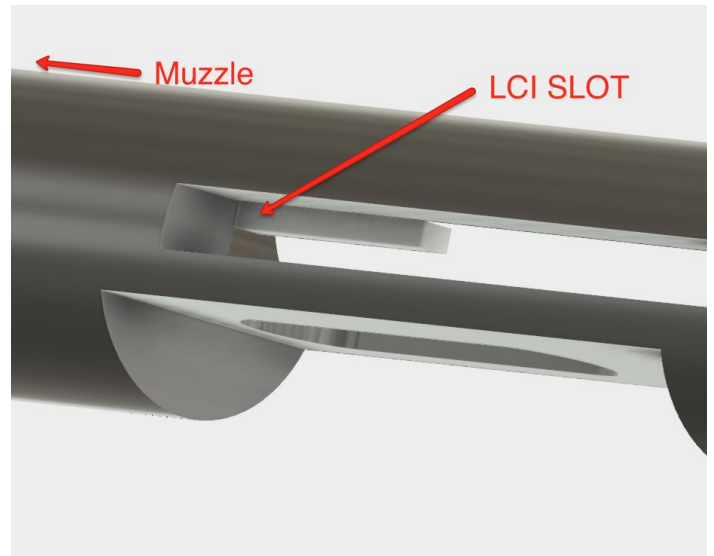

6. To sand the edge of the LCI, place the LCI in a vice to protect the crisp edges of the exposed surface and sand or file the face of the flag edge until a proper fit is achieved. Checking the fit as sanding progresses will provide the optimum fit.

